



VIP-Weco No Dig Pipe Repair Seal Technical Specifications



Since the 1960s VIP-Weco internal pipe seals have been used worldwide for trenchless rehabilitation of pipes and sewers for industrial water, drinking water, waste water, fuel and gas.

VIP-Weco use WRAS approved material, comply fully with BS6920 and have a typical life expectancy of 50+ years.

Diameter Ranges

Non walkable: DN185 to DN599
Walkable: DN600 to DN3500

Pressure Ranges

Exfiltration; Up to 20 bar
Infiltration; Up to 2.0 bar

Both infiltration and exfiltration maximum pressures are dependent upon the host pipe material.

Test valves can be fitted upon request.

Installation Time

Typical installation time of 40mins.

Installation by VIP Polymers approved contractor or installation training can be provided.

Pipeline Suitability

- > Ductile Iron
- > Steel
- > GRP
- > Plastic
- > Clay
- > Concrete

Pipe Profiles

- > Egg shaped
- > Circular
- > Ellipse
- > Mouth
- > Bespoke angles

Temperature Range

-10°C to 140°C

Life Expectancy

Typical life expectancy of 50+ years

Applications

Joint repair, end liner sealing/repair for re-lined pipes.

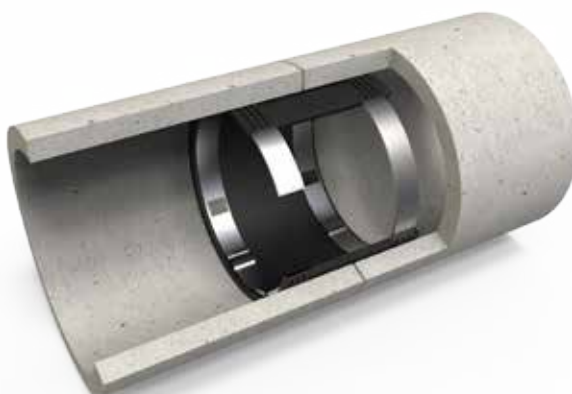



VIP-Weco No Dig Pipe Repair Seal Technical Specifications



Rubber

Material: EPDM
 Colour: Black
 Hardness: 70+/-5 SHORE A

Physical Properties

In accordance with **BS EN 681-1 Elastomeric seals - Materials requirements for pipe joint seals used in water and drainage applications.** (Kitemark)

Rubber Sleeve Dimensions

Total Width:	280mm	480mm
Web width:	150mm	350mm
Sleeve thickness:	6mm	6mm

Potable Approvals

BS6920 (UK & Ireland)
 WRAS material approval (UK & Ireland)
 ACS (France)

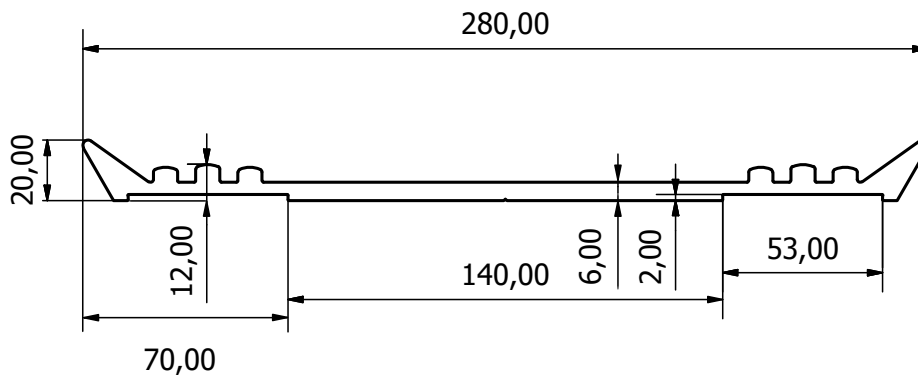

Compound: CVE69

Specification: EN 681-1 / WA/WC/70

PROPERTY	TEST METHOD	UNIT	RESULTS	SPEC
Hardness (Micro)	ISO 48	IRHD	70	70+/-5
Tensile	ISO 37	Mpa	12.3	9 min
Elongation	ISO 37	%	298	200 min
C.S 70 hrs @ 23°C	ISO 815	%	8.1	15 max
C.S 22 hrs @ 70°C	ISO 815	%	15.2	20 max
C.S 72 hrs @ -10°C	ISO 815	%	30.2	50 max
Stress Relaxation 7 days @ 23°C	ISO 3384	%	11.5	16 max
Stress Relaxation 100 days @ 23°C	ISO 3384	%	18.2	23 max
Water 7d @ 70°C	ISO 1817	%	+1.5	+8/-1
Ageing 7d @ 70°C	ISO 188			
Hardness change	ISO 48	IRHD	+2	+8/-5
Tensile % change	ISO 37	%	-1.2	-20
Elongation % change	ISO 37	%	-9.6	+10/-30
Ozone resistance	ISO 1431-1		No cracks	No cracks

Alternative Materials

For applications where aggressive chemicals may be present, NBR (Nitrile) rubber is available at request.



VIP-Weco No Dig Pipe Repair Seal Technical Specifications



Tension Band Materials

Made of stainless steel which is pickled to avoid corrosion, the tension bands used in the VIP-Weco seal are available in 304 (1.4301) and 316 (1.4401) grades. Further grades for different applications are available on request.

Thickness

5mm or 8mm thickness

Components

Supplied as either single (185-1050ID), two-piece (1200-1800ID) or three-piece (1900ID +) for ease of transportation through the pipe.

Chemical Composition

Steel Grade	304 (1.4301)	316 (14401)
Element	% Present	
Chromium (Cr)	17.50 - 19.50	16.50 - 18.50
Nickel (Ni)	8.00 - 10.50	10.00 - 13.00
Molybdenum (Mo)	N/A	2.00 - 2.50
Manganese (Mn)	0.0 - 2.00	0.0 - 2.00
Silicon (Si)	0.0 - 1.00	0.0 - 1.00
Nitrogen (N)	0.0 - 0.11	0.0 - 0.11
Carbon (C)	0.0 - 0.07	0.0 - 0.07
Phosphorous (P)	0.0 - 0.05	0.0 - 0.05
Sulphur (S)	0.0 - 0.03	0.0 - 0.03
Iron (Fe)	Balance	Balance

Generic Physical Properties

Steel Grade	304 (1.4301)	316 (14401)
Property	Value	
Density	8.00 g/cm ³	8.0 g/cm ³
Melting Point	1450 °C	1400 °C
Thermal Expansion	17.2 x10 ⁻⁶ /K	15.9 x10 ⁻⁶ /K
Modulus of Elasticity	193 GPa	193 GPa
Thermal Conductivity	16.2 W/m.K	16.3 W/m.K
Electrical Resistivity	0.072 x10 ⁻⁶ Ω .m	0.074 x10 ⁻⁶ Ω .m

Mechanical Properties (EN 10088-3:2005 Max Diameter / Thickness 160mm)

Steel Grade	304 (1.4301)	316 (14401)
Property	Value	
Proof Stress	190 Min MPa	200 Min MPa
Tensile Strength	500 to 700 MPa	500 to 700 MPa
Elongation A50 mm	45 Min %	40 Min %
Hardness Brinell	215 Max HB	215 Max HB